

IV
2009

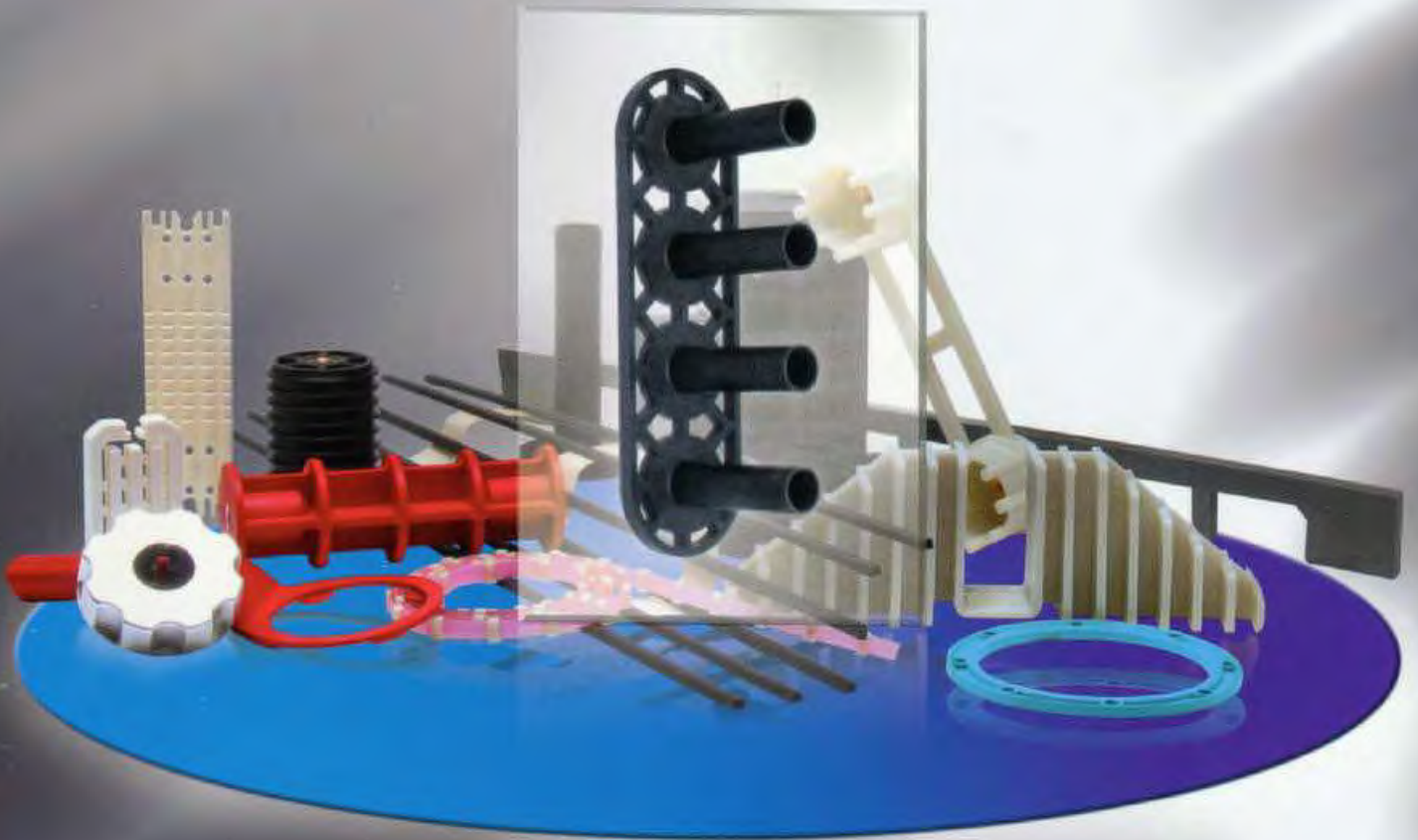

pioch

www.pioch.com

Sommaire - Summary - Inhaltsangabe - Sumario

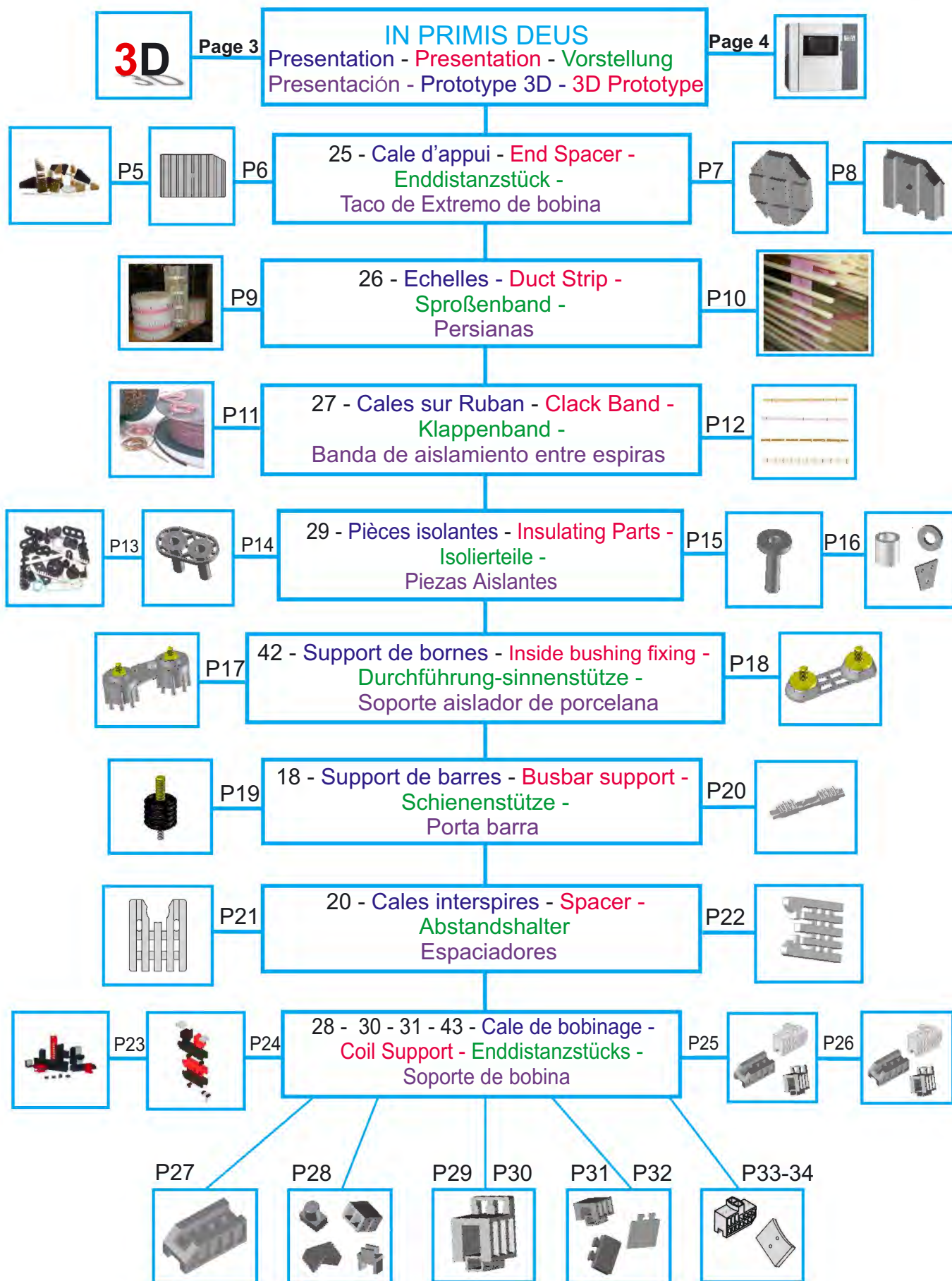

IN PRIMIS DEUS

Plusieurs familles de produits sont regroupées dans ce catalogue :

Several Product families are given in this catalog :

In diesem atalog sind mehrere Familien von Produkten zusammengefibt :

En este catalogo se agrupan varias familias de productos :

<p>Transformateur "HUILE" Oil immersed Transformer Öltransformator Transformator en aceite</p>	<p>25 26 27 29 42</p>	<p>ECS Calage d'extrémité DBC Canal intercoches CBS Cales sur ruban SIP Plaque isolante Plaque à tubes Tubes à collerette Rondelles isolantes BIP Support de bornes</p>	<p>ECS End Spacer DBC Duct Strip CBS Clack band SIP Insulating Plate Pipe Plate Pipe Flange Insulating Washers BIP Inside bushing Fixing</p>	<p>ECS Enddistanzstücks DBC Sproßenhad CBS Klappenband SIP Sonderisolierteile Isolierplatte mit rohr Rohrtülle Isolierscheibe BIP Durchführung-sinnenstütze</p>	<p>ECS Taco de extremo de bobina DBC Persianas CBS Banda de aislamiento entre espiras SIP Piezas aislantes especiales Placa con tubos Tubo con collarin Arandela Soporte aislador porcelana</p>
<p>Transformateur "SEC" Dry type Transformer Trockentransformator Transformator Tipo Seco</p>	<p>18 20</p>	<p>BAS Support de BARRE Support jeu de BARRES CIS Peigne Cales interpires</p>	<p>BAS Busbar Support CIS Comb Spacers</p>	<p>BAS Schienenstütze CIS Kabelzopf Abstandshalter</p>	<p>BAS Porta barra CIS Peine Espaciadores</p>
<p>Transformateur "Resine" Cast resin Transformer Gießharztrasformator Transformator encapsulado</p>	<p>28 28 30 31 43</p>	<p>CCS Assemblage support de bobine CCS Cale de base Pièces de liaison "N" Cale support de bobine "H" Cale support de bobine "P" Cale support de bobine Amortisseur CCS Cale monobloc</p>	<p>CCS Assembly of coil supports CCS Bottom Spacer Connecting parts "N" Coil Support "H" Coil Support "P" Coil Support Shock Absorber CCS Block Support</p>	<p>CCS Anordnung Isolierstück CCS Grundkeile Anschlußstück "N" Enddistanzstücks "H" Enddistanzstücks "P" Enddistanzstücks Stoßdämpfer CCS Aufbaublock</p>	<p>CCS Conjunto soportes de bobina CCS Taco de base Pieza de conexion "N" Soporte de bobina "H" Soporte de bobina "P" Soporte de bobina Amortiguador CCS Taco bloque</p>

Nous pouvons étudier toutes pièces répondant à vos besoins.

We can study all parts responding to your needs.

Wir können sämtliche teile entwickeln, um Ihrem Bedarf zu entsprechen.

Podemos estudiar todas las piezas que respondan a sus necesidades.

Réalisation rapide de prototype en ABS et matières pour haute température, classé feu

Pioch can quickly manufacture ABS prototype and high temperature materials, classified fire

Presentation - Vorstellung - Presentación

Toutes les familles de produits présentées, qu'elles soient dédiées aux transformateurs de type Huile, Sec ou enrobé sont respectueuses de l'Environnement.

Depuis l'origine de leur conception et jusqu'à leur utilisation par nos clients, nos fabrications sont en effet pensées et réalisées dans le souci constant de préserver la nature.

Entièrement recyclables, elles contribuent également aux efforts des producteurs et utilisateurs de transformateurs qui ont le même objectif écologique.

All products families presented in this catalogue, dedicated to Oil filled, Dry type or Cast Resin transformers, are environmentally friendly.

From their early conception and until they are used by customers, our productions are indeed thought and realized with a constant concern to preserve nature.

Fully recyclable, they also contribute to the efforts of the transformers manufacturers and users who have the same ecological target.



Des produits respectueux de l'environnement

Depuis plus de 30 ans, Pioch a développé et fabriqué ces produits dans un souci constant de qualité, mais aussi de respect de l'environnement.

Du choix des matériaux jusqu'à l'emballage, chaque étape du processus de fabrication est pensée pour éviter le gaspillage, minimiser les déchets et empêcher la pollution.

La technologie même de ces produits les rend utilisables indéfiniment dans le temps.

Products respectful of the environment

For more than 30 years, Pioch has been developing and manufacturing these products in a constant concern of quality, but also of respect of the environment.

From choice of materials to packing, each step of the manufacturing process is thought to avoid waste, minimize losses and prevent from pollution.

The technology of these products itself makes them indefinitely usable in time.

Transformateurs "Huile" / Oil immersed Transformateur / Öltransformator / Transformator en aceite
 END Spacer - Eenddistanzstück - Taco de Extremo de Bobina

Référence - Reference Referenz - Referencia	A	B	C	D	E	F	G	H	I
25240368	368	98	40	82	82	3	146	46	40
25240265	265	74	40	84	58	3	125	19	40
25240238	238	74	40	56	30	3	96	18	40
254020058	200	40	40	64	58	3	135	18	40
253015054	150	40	30	60	54	3	100	18	30
25210195/R	196	64	10	52	40	3	100	29	5
25210196/R	196	64	10	52	40	2.5	100	29	35

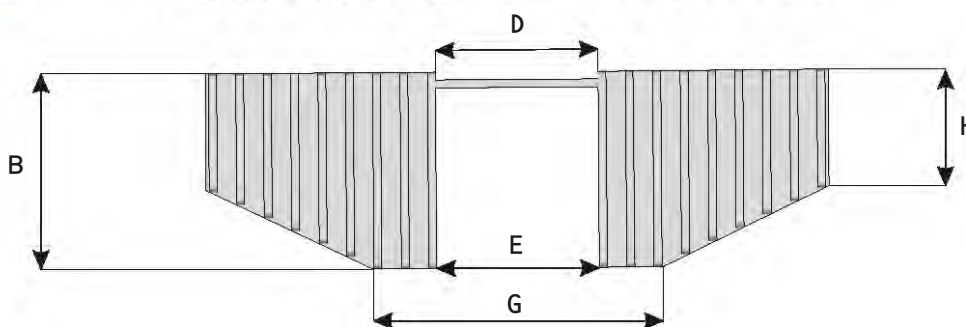
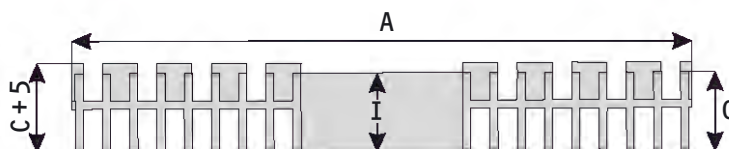

252101196

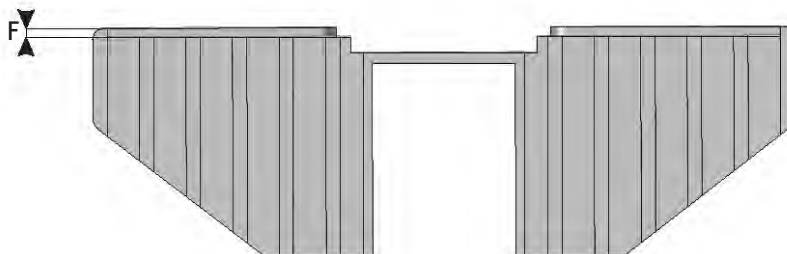

25 - ECS - CALES d'appui de BOBINAGE



Transformateurs "Huile" / Oil immersed Transformateur / Öltransformator / Transformator en aceite
 END Spacer - Eenddistanzstück - Taco de Extremo de Bobina

Référence - Reference Referenz - Referencia		A	B	C	D	E	F	G	H	I
25D57120	01	120	77	57	67	30	61	38	9	4
25G57120	01	120	77	57	67	30	61	38	9	4
25D40119	01	119	77	40	67	30	61	38	9	4
25G40119	01	119	77	40	67	30	61	38	9	4
25D35075	01	75	77	35	72	15	31	38	9	5
25G35075	01	75	77	35	72	15	31	38	9	5
25DG35075	01	75	77	35	72	15	31	38	9	5
25DG040120	**01	120	77	40	66	29	60	44	9	4

** = Doigt mobile - moving finger - zapfen - dedo movil

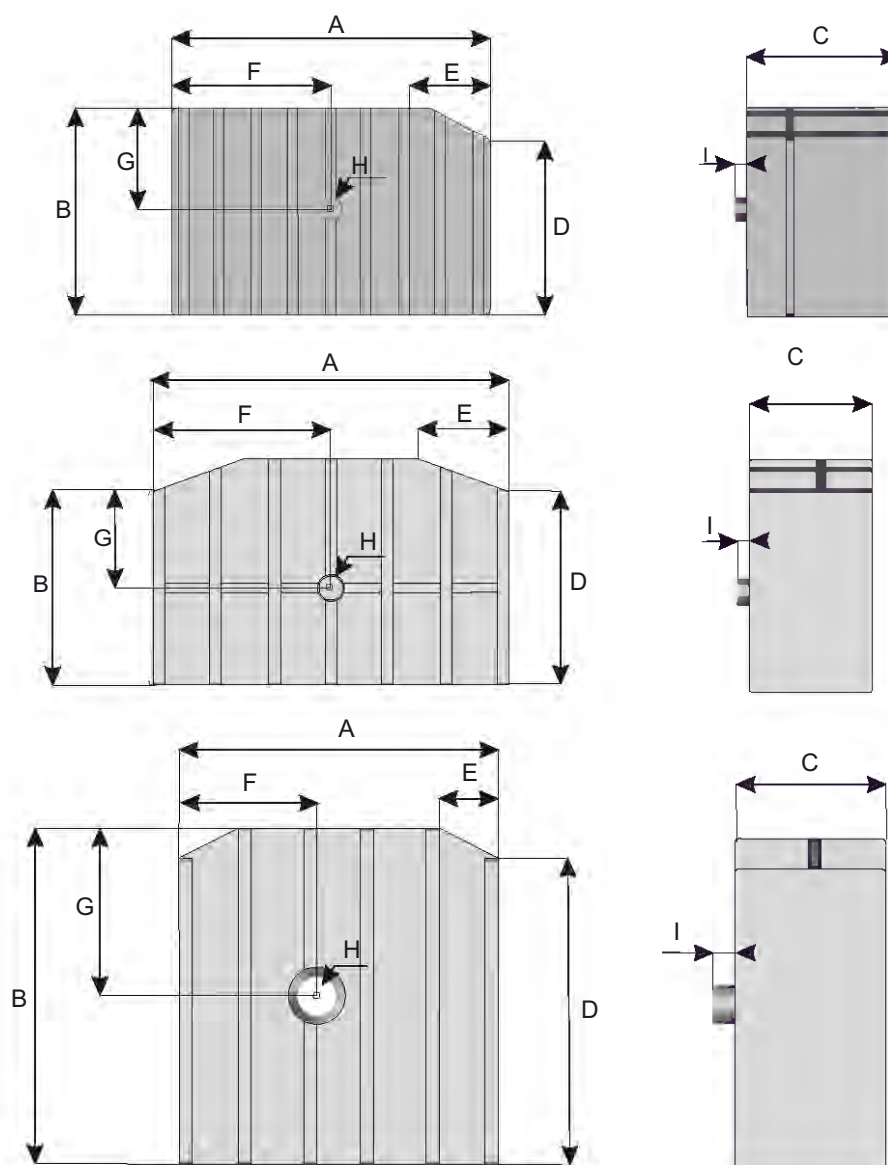

Transformateurs "Huile" / Oil immersed Transformateur / Öltransformator / Transformator en aceite
 END Spacer - Eenddistanzstück - Taco de Extremo de Bobina

Référence - Reference Referenz - Referencia	A	B	C	D	E	F	G	H
25APD85	100	100	96	96	34	44	12/7	17
25APG86	100	100	96	96	34	44	12/7	17
25APD87	112	112	110	110	47	56	12/7	17
25APG88	112	112	110	110	47	56	12/7	17

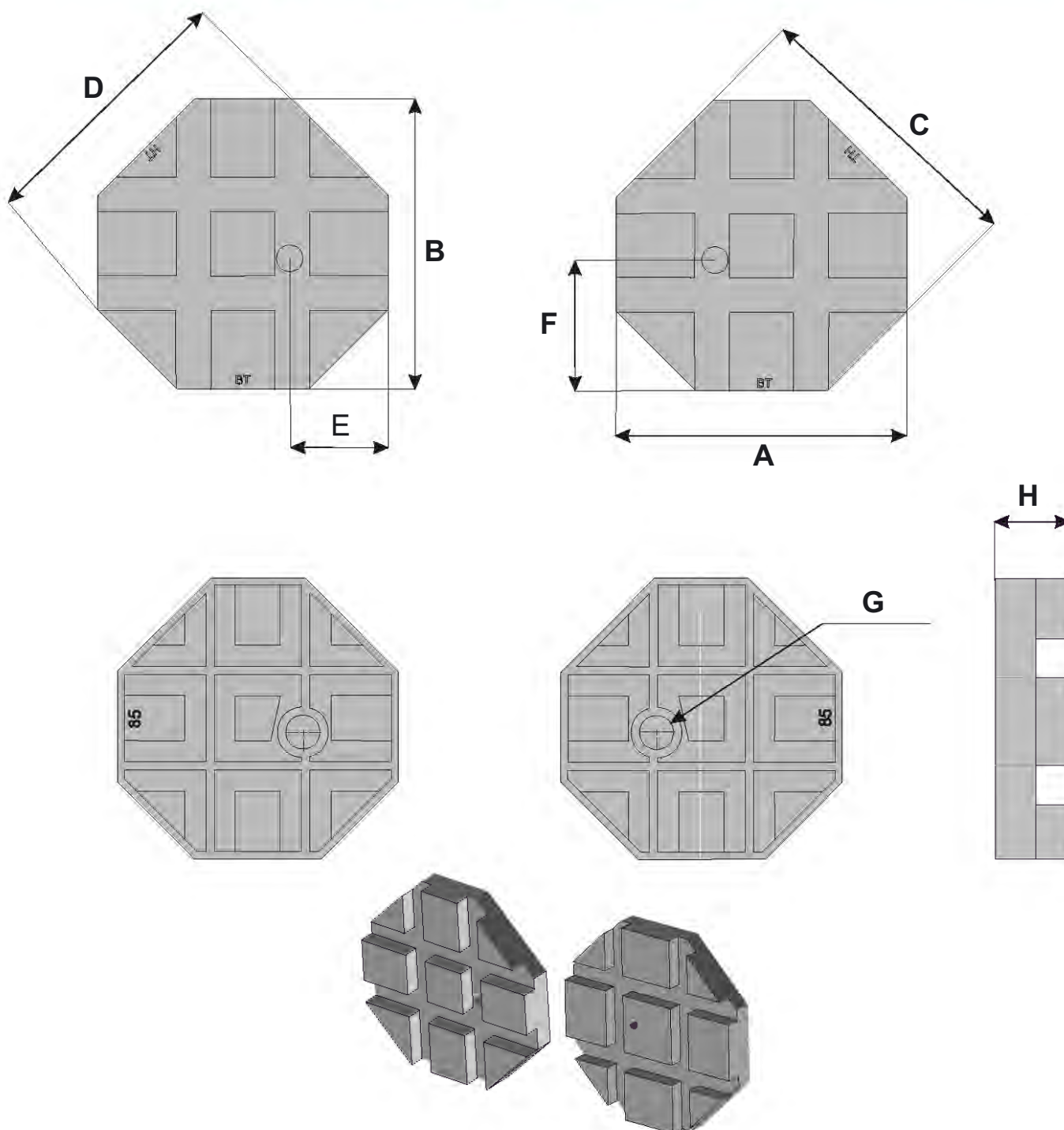

25 - ECS - CALES d'appui de BOBINAGE

Transformateurs "Huile" / Oil immersed Transformateur / Öltransformator / Transformator en aceite
 END Spacer - Eenddistanzstück - Taco de Extremo de Bobina

Référence - Reference Referenz - Referencia	A	B	C	D	E	F	G	H
25APD91	78	88	24	24	44	40	12/7	17
25APG92	78	88	24	24	44	40	12/7	17
25APD24	74	66	24	24	37	36	10/7	17
25APG23	74	66	24	24	37	36	10/7	17

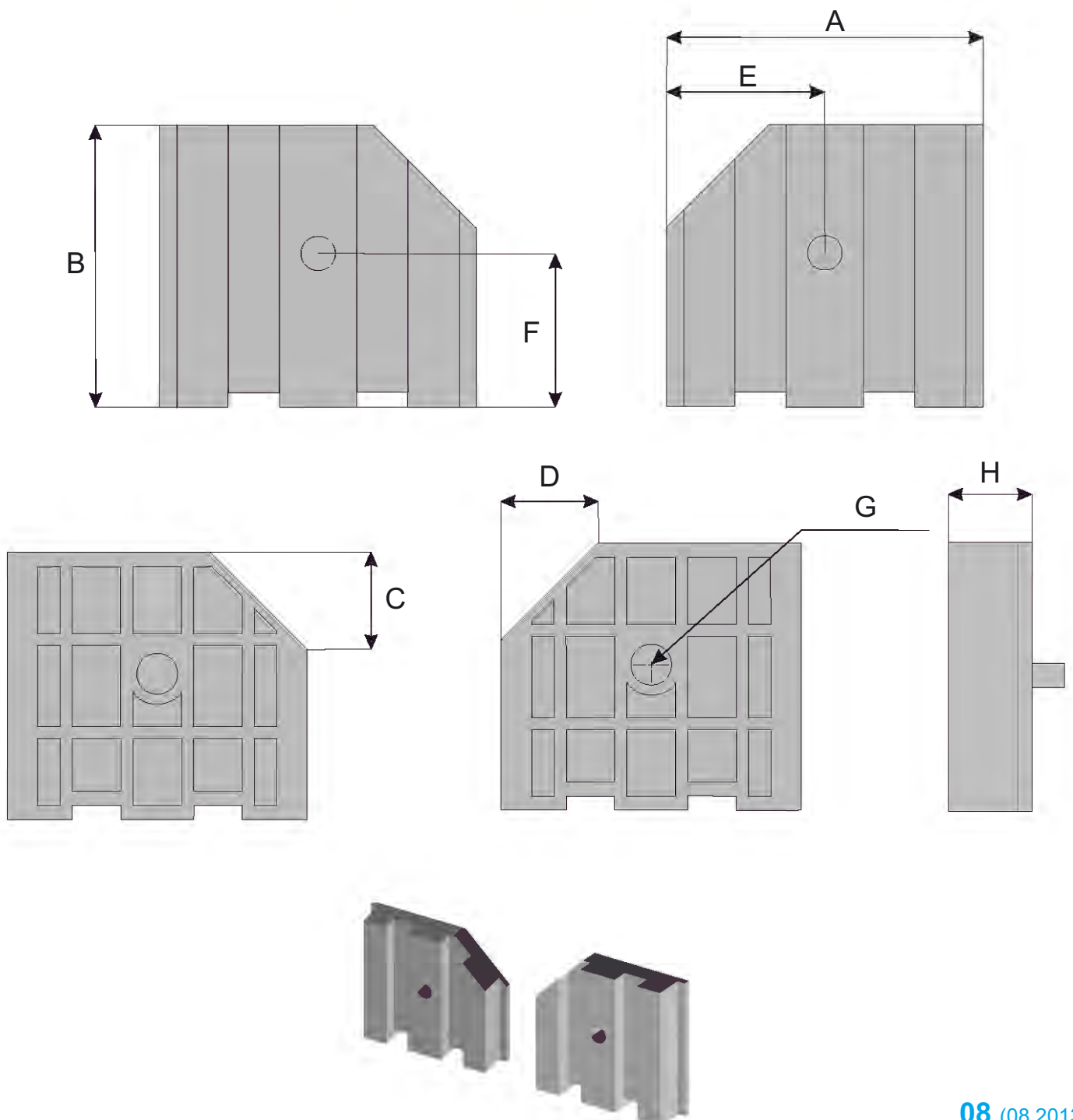

Transformateurs "Huile" / Oil immersed Transformateur / Öltransformator / Transformator en aceite

Duct Strip - Sproßenband - Persianas

Pour une utilisation dans les transformateurs à huile, ces échelles permettent d'améliorer la circulation de l'huile entre deux écrans.

Used in oil immersed transformers, These duct strips allow improving the circulation of oil between two screens.

La forme et le pas des barrettes ont été étudiés pour une meilleure répartition des charges. Les angles des barrettes sont arrondis.

The shape and pitch of the bars were studied for a better distribution of the loads. Rounded bar edges.

En cas de choc thermique et électrique, les barrettes ont une bonne résistance à la flexion et à l'écrasement.

In event of electric or thermal shock, the bars have a good resistance against bending and crushing.

Leur facilité de pose assure un gain très appréciable de productivité lors du montage. They are easy to install, assuring a very significant gain in productivity during mounting.

Elles sont livrées en rouleaux de 50 mètres maxi ou suivant besoin, sur un tube d'enroulement de Ø 60 & 76

They are delivered in rolls having a maximum length of 50 m or according to requirements on a winding tube of Ø 60 & 76.

Barrettes - Classe B & F - PA 4 Bars - Class B & F - PA 4			
Sur ruban polyester 180° - largeur 30mm On polyester tape 180° - 30 mm wide			
Nombre de ruban : 2 Number of tapes : 2			
Pas de 26 Pitch of 26			
Longueur barette Bar lengt	Epaisseur barette Bar width	Longueur barette Bar lengt	Epaisseur barette Bar width
200 à 380	Ep. / Thickness 3	250 à 380	Ep. / Thickness 2.25
200 à 380	Ep. / Thickness 4	250 à 380	Ep. / Thickness 3.25
		250 à 380	Ep./ Thickness 4.25
320 à 700	Ep. / Thickness 4		
220 à 530	Ep. / Thickness 5		
Pas de 40 Pitch of 40			
320 à 520	Ep. / Thickness 7 R 0.5		
520 à 700	Ep. / Thickness 7 R 0.5		
Nombre de ruban : 3 Number of tapes : 3			
Pas de 26 Pitch of 26			
370 à 700	Ep. / Thickness 3	405 à 720	Ep. / Thickness 2.25
320 à 700	Ep. / Thickness 4	405 à 720	Ep. / Thickness 3.25
480 à 700	Ep. / Thickness 5	405 à 720	Ep./ Thickness 4.25



Transformateurs "Huile" / Oil immersed Transformateur / Öltransformator / Transformator en aceite

Duct Strip - Sproßenband - Persianas

Für die Anwendung in Öltransformatoren

Diese Leitern verbessern den Ölfluß zwischen zwei Blendschirmen

Form und Abstand der Stege wurden entwickelt, um eine bessere Verteilung der Lasten zu erreichen. Die Kanten der Stege sind abgerundet.

Bei Wärme- oder Elektroschocks weisen die Stege eine gute Biege- und Bruchfestigkeit auf.

Die Leichtigkeit des Einbaus gewährleistet einen beachtlichen Produktivitätsgewinn bei der Montage.

Sie werden in Rollen von max. 50 m oder auf Wickelrohr Ø 60 & 76 geliefert.

Para una utilización en los transformadores en aceite

Estas persianas permiten mejorar la circulación del aceite entre dos pantallas

La forma y el paso de las barras han sido estudiadas para una mejor distribución de las cargas. Los ángulos de las barras son redondos

En caso de choque térmico y eléctrico, las barras tienen una buena resistencia a la flexión y al aplastamiento.

Su facilidad de colocación garantiza un importante ahorro de productividad durante el montaje.

Se suministran en rollos de 50 m. como máximo o en caso necesario en tubos de enrollamientos de 60 y 76 de diámetro.

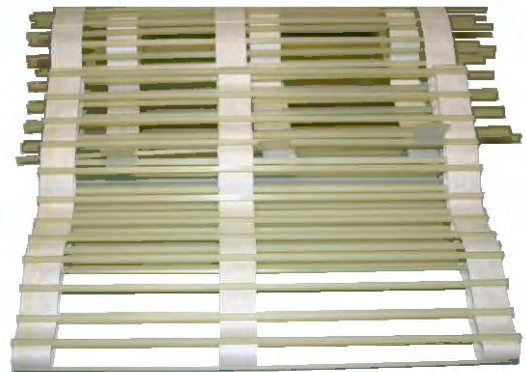

Transformateurs "Huile" / Oil immersed Transformateur / Öltransformator / Transformator en aceite

Clack Band - Klappenband - Banda de aislamiento entre espiras

En utilisation pour les très gros bobinages, pour isolation et espacement des enroulements.

Used for very large windings, for insulation and spacing of windings.

Mise en place très simple lors du bobinage des conducteurs.

Very easy to install during wire winding.

La forme des cales, sans angle vif, évite d'endommager l'isolant des méplats bobinés;

The spacer shape - without sharp edges prevents damaging the insulation of coiled flat wires ;

Permettent une très bonne circulation du diélectrique.

Allows a very good dielectric circulation

Cales - classe B - PA 1				Cales - Classe F - PA 4			
Sur polyester 155°				Sur polyester 155°			
Pas de 40				Pas de 40			
Code	N°	Ruban en mm	Cales en mm	Code	N°	Ruban en mm	Cales en mm
27060440	1	4	6x4x4	27F60440	1	4	6x4x4
27090440	2	6	9x4x4	27F90440	2	6	9x4x4
27120440	3	6	12x4x4	27F12440	3	6	12x4x4
27170440	4	12	17x4x4	27F17440	4	12	17x5x5

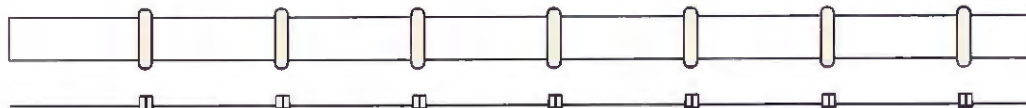
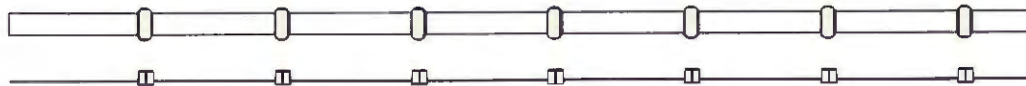
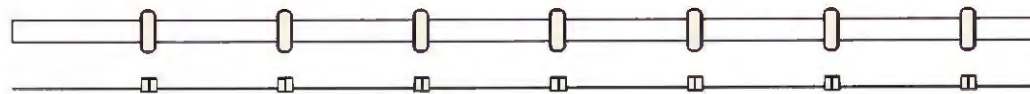
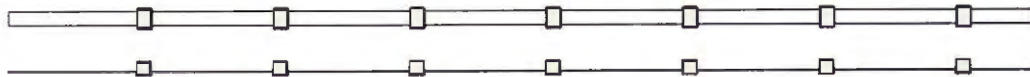

Transformateurs "Huile" / Oil immersed Transformateur / Öltransformator / Transformator en aceite

Clack Band - Klappenband - Banda de aislamiento entre espiras

In der Anwendung für sehr große Wicklungen, für die Isolierung und den Abstand der Wicklungen

Sehr einfacher Einbau beim Wickeln der Leiter

Die Form der Beilagen ohne scharfe Kanten vermeidet Beschädigungen an der Isolierung der gewickelten Flachstellen.

Erlaubt einen sehr guten Durchfluß des Dielektrikums

Se utilizan para los bobinados muy grandes, para aislamiento y espaciamento de los enrollamientos.

Colocación muy sencilla durante el bobinado de los conductores.

La forma de los tacos, sin ángulo vivo, evita dañar el aislante de los alambres eléctricos planos de las bobinas;

Permite una circulación del dieléctrico muy buena.

Cales - classe B - PA 1				Cales - Classe F - PA 4			
Sur transformerboard 130°				Sur polyester 155°			
Pas de 25				Pas de 25			
Code	N°	Ruban en mm	Cales en mm	Code	N°	Ruban en mm	Cales en mm
270810325	6	8	10x4.7x3.25	27F081025	6	8	10x4.7x3.25
271218325	7	12	18x4.7x3.25	27F1218325	7	12	18x4.7x3.25
270408225	8	4	8x5x2.25	27F0408225	8	4	8x5x2.25

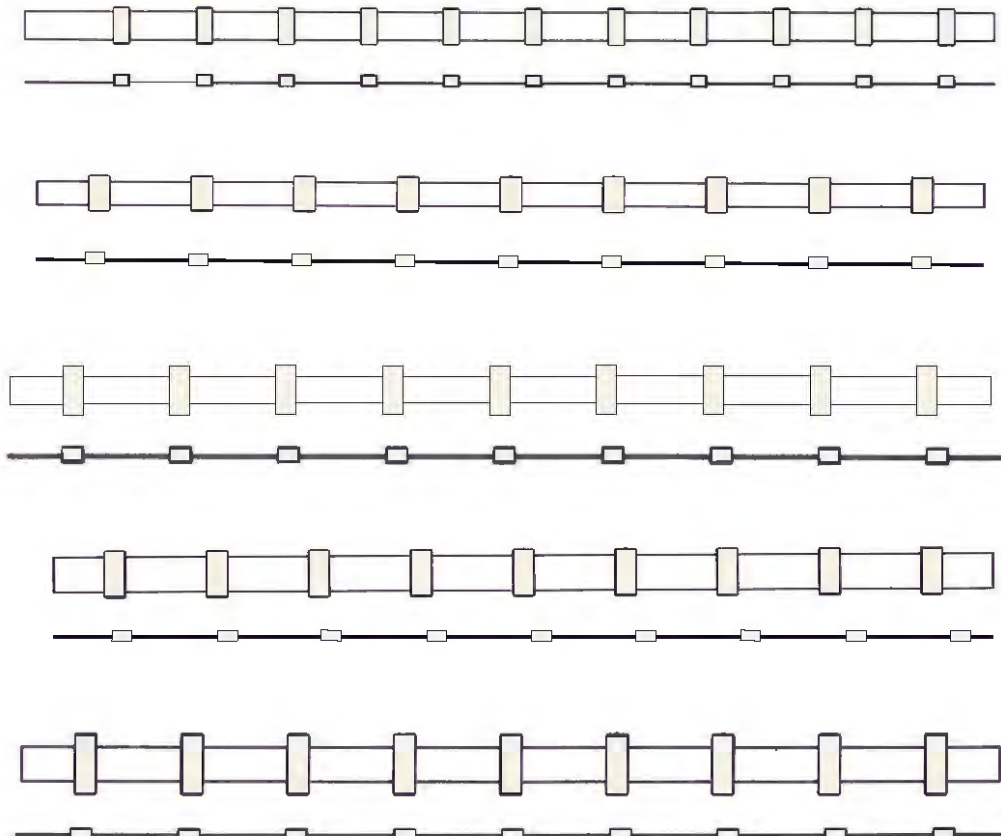

Insulating Plate - Isolierplatte - Placa Aisladora

Référence - Reference Referenz - Referencia	Modèle - Type Muster - Modelo	A	B	Epaisseur - Thickness Stärke - Espesor	C	∅ & nombre - Number Menge - Número
2910P15290	1	152	90	10	62	36 - 2
2910P14280	2	142	80	10	62	27 - 2

Référence - Reference Referenz - Referencia	Modèle - Type Muster - Modelo	A	B	Epaisseur - Thickness Stärke - Espesor	C	∅ & nombre - Number Menge - Número
2910P21490	3	214	90	10	62	36 - 3
2910P20480	4	204	80	10	62	27 - 3

Référence - Reference Referenz - Referencia	Modèle - Type Muster - Modelo	A	B	Epaisseur - Thickness Stärke - Espesor	C	∅ & nombre - Number Menge - Número
2910P27690	5	276	90	10	62	36 - 4
2910P26680	6	266	80	10	62	27 - 4

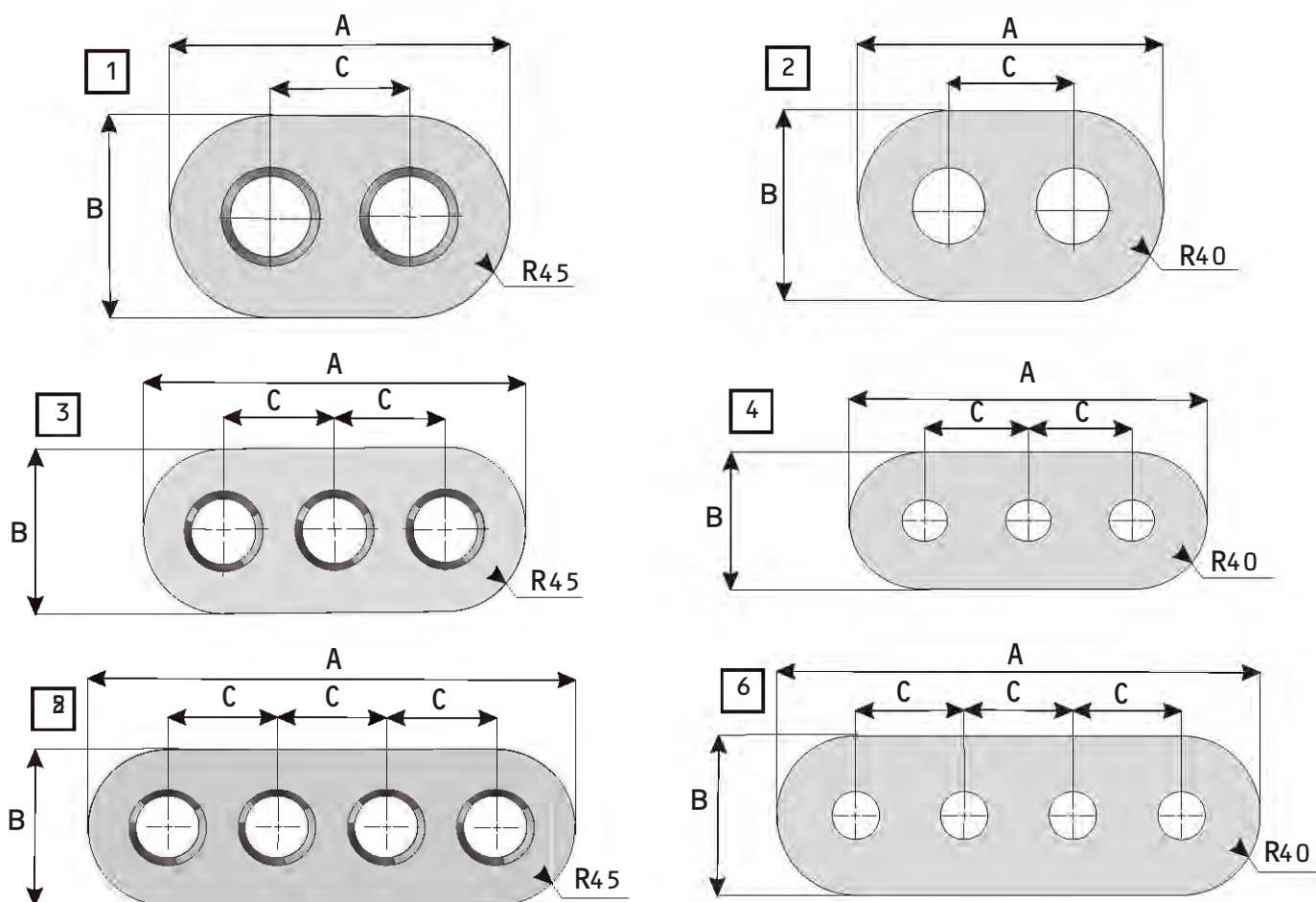

Transformateurs "Huile" / Oil immersed Transformateur / Öltransformator / Transformator en aceite

Pipe Plate - Isolierplatte Mit Rohr - Placa Con Tubos

	Référence - reference Referenz - referencia	A	B	C	D	E	F	G
1	29PT11428010004	142	80	62	10	100	21	25
2	29PT12048010004	204	80	62	10	100	21	25
3	29PT12668010004	266	80	62	10	100	21	25

Pour M20 - for M20 - für M20 - para M20

classe F

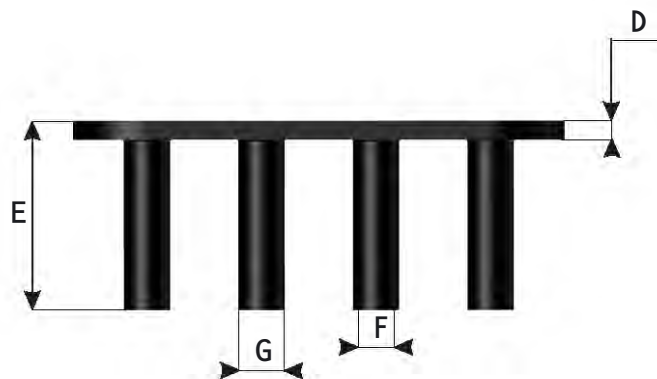
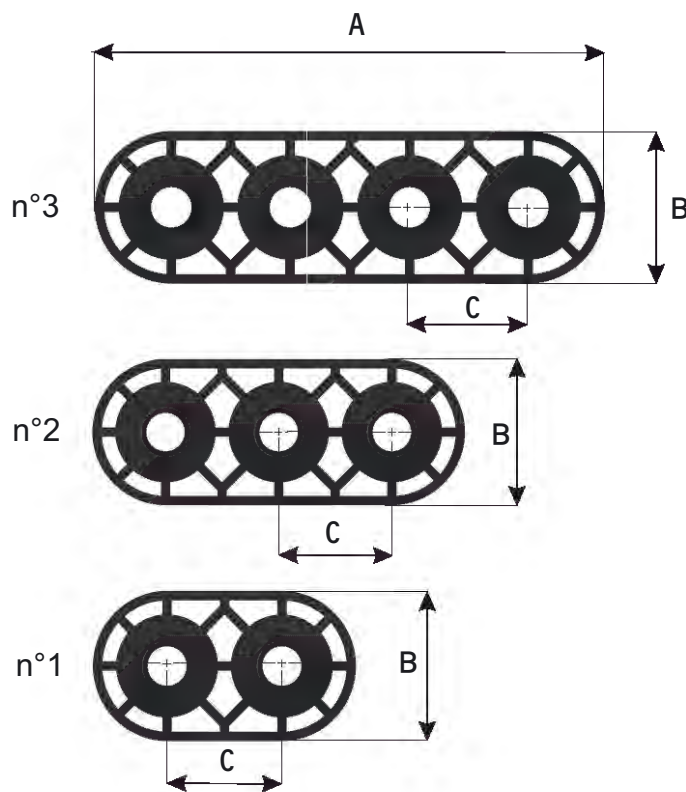

Transformateurs "Huile" / Oil immersed Transformateur / Öltransformator / Transformator en aceite
 Flange Pipe - Rohrtülle - Tubo Con Collarin

Référence - Reference Referenz - Referencia	A	B	C	D	E
29T031045	31	45	10,5	13,5	10
29T038050	38	50	11	14	10
29T040050	40	50	13	16	10
29T040070	40	70	13	16	10
29T050030	50	30	17	22	10
29T050040	50	40	17	22	10
29T050050	50	50	17	22	10
29T050070	50	70	17	22	10
29T060048	60	48	21	25	10
29T060070	60	70	21	25	10
29T060095	60	95	21	25	10
29T060125	60	125	21	25	10
29T065035	65	35	25	30	10
29T065050	65	50	25	30	10
29T065060	65	60	25	30	10
29T065070	65	70	26	30	10
29T065300	65	300	25	30	10
29T040050/6	40	50	18	22	6
29T040070/6	40	70	18	22	6
29T050065/6	50	65	28	34	6
29T050080/6	50	80	22	28	6
29T050100/6	50	100	22	28	6
29T050120/6	50	120	22	28	6
29T060050/6	60	50	26	32	6
29T070050/6	70	50	32	38	6
29T110075	110	75	26	34	4
29T130030	130	30	48	52	2
29T150050	150	50	48	52	2
29T150051	150	51	48	52	2

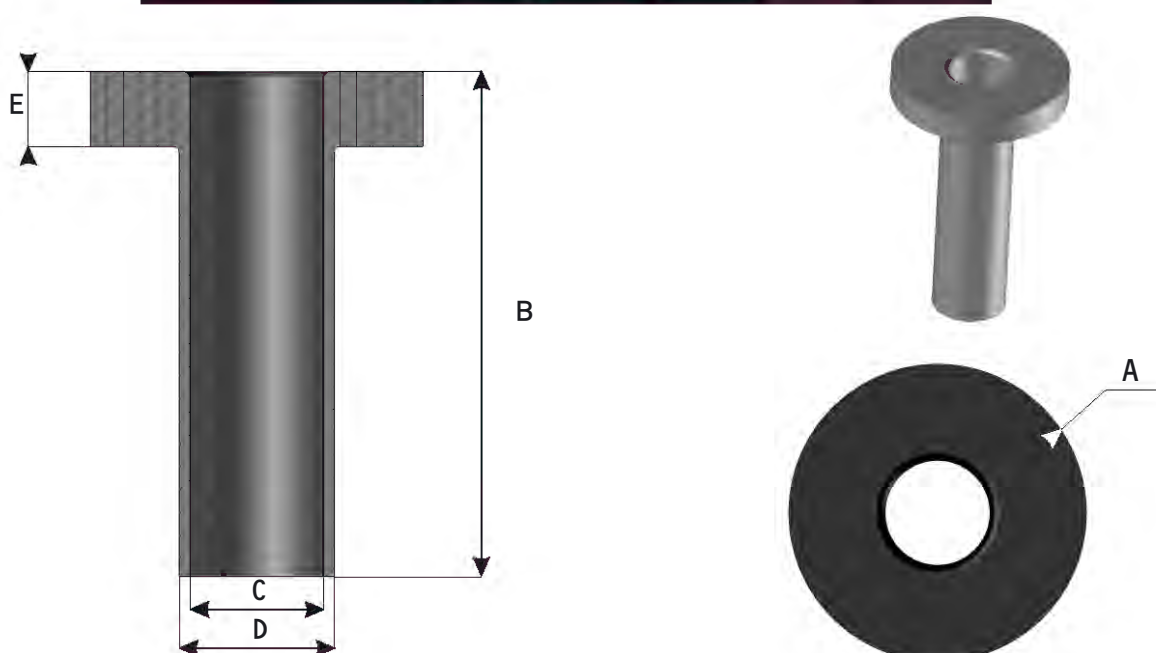

29 - SIP -Pièces diverses isolantes

Transformateurs "Huile" / Oil immersed Transformateur / Öltransformator / Transformator en aceite

Rondelles - Washer - Isolierscheibe - Arandela

Code		ØInt.	ØExt.	H
29R03268	Rondelles isolante 03268	18	50	7
29R03598	Rondelles isolante 03598	14	50	7
29R04568	Rondelles isolante 04568	18	40	7
29R04576	Rondelles isolante 04576	21	40	7
29R04578	Rondelles isolante 04578	22	45	7
29R04728	Rondelles isolante 04728	24	45	7
29R86025	Rondelles isolante 08625	10	25	7
29R06531	Rondelles isolante 653112	31	65	12

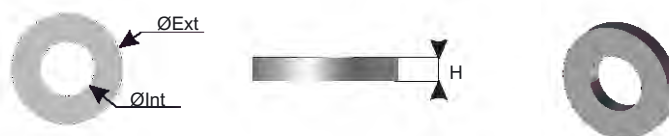

Tubes - Pipe - Rohr - Tubo

29T03298	Tube isolant 03298	18	28	33
29T03318	Tube isolant 03318	18	28	24
29T86038	Tube isolant 86038	16.2	23.8	23
29T86041	Tube isolant 86041	16.2	23.8	39



Limiteur - Limit - Begrenzung - Limitador

29L86031	Limiteur isolant 86031	162	260	6
29L86032	Limiteur isolant 86032	138	230	6
29L1453510	Limiteur isolant 145.10/1	35	145	10

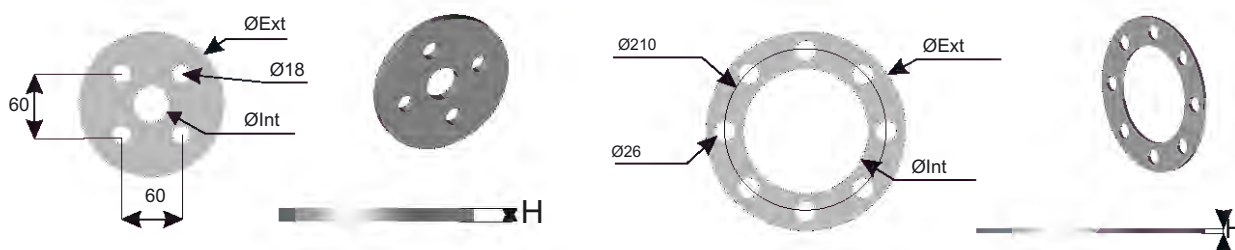

Fixation Isolante - Fixing - Festlegung - Fijación

29T031045	Fixation isolante 86023	102	52	10
-----------	-------------------------	-----	----	----

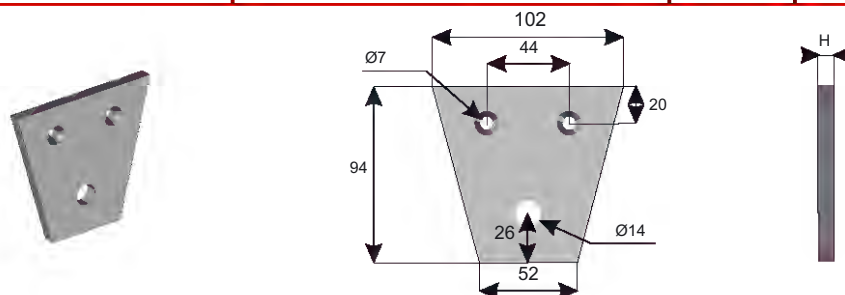

Inside Bushing Fixing - Klemmenträger - Soporte de bornes

Pour transformateur huile, support de traversées porcelaine BT,
 -Pour tout standard de 160A à 630A
 -Modèle simple et multiple à entraxe fixe de 55 à 150.

-Simplifie la méthode de fixation des traversées porcelaine.
 -La réduction du nombre de pièces nécessaires et la rapidité du montage permettent une diminution significative des coûts d'installation.
 -Très robuste.
 -Permet une bonne circulation de l'huile.

-Tige laiton pour la fixation(1), est fournie sur demande.

For an oil immersed transformer, LV porcelain Bushing fixing:
 -for any standard from 160 A to 630A ;
 -single and multiple types with fixed spacing from 55 to 150.

- Simplifies the fixing method for porcelain Bushings;
 - Reduces the number of required parts and assembling time, and so significantly reduces fitting costs;
 - Very robust;
 - Allows good oil circulation;

- Brass rod for the fixing (1), is supplied on request.

Classe B - Classe d'isolement : 1Kv				
Code	Entraxe	Bornes laiton (1)		
		Ø	Hauteur mm	
4200000	Mono			
4200008	Mono	8		13
4200012	Mono	12		27
4200016	Mono	16		24
42055QA208	55	8		13
42055QA212	55	12	15	27
42075208	75	8		13
42075212	75	12	15	27
42080208	80	8		13
42080212	80	12	15	27
42150208	150	8		13
42150212	150	12	15	27
42V088090*	Min80 Max 100	8		13
42V128090*	Min80 Max 100	12	15	27

* Variable

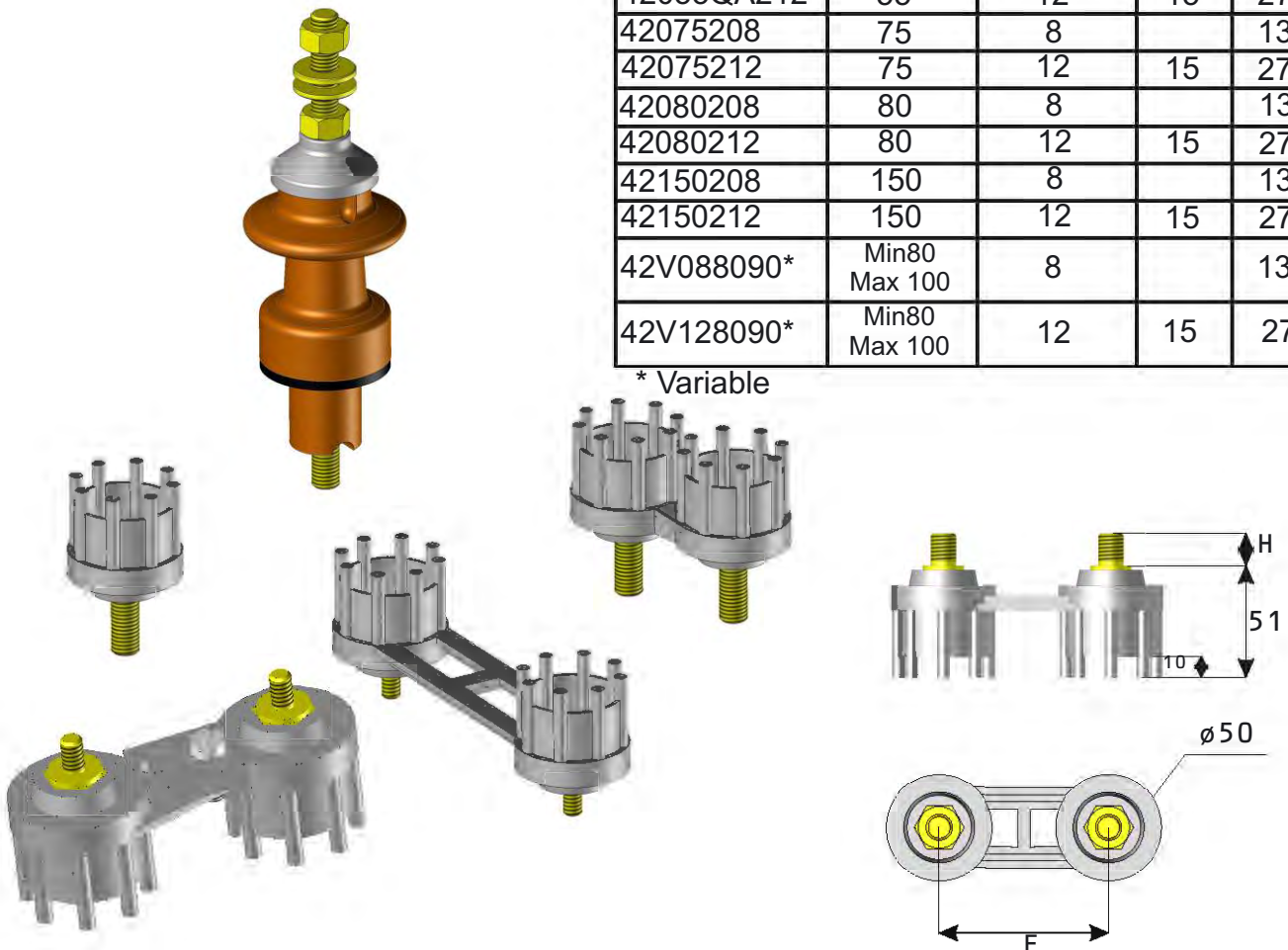

Transformateurs "Huile" / Oil immersed Transformateur / Öltransformator / Transformator en aceite

Inside Bushing Fixing - Klemmenträger - Soporte de bornes

Für Öltransformator, Träger für NS-Durchführungen aus Porzellan

-für jeden Standard von 160 A bis 3150 A

-einfaches und vielfältiges Modell mit festem Achsabstand von 55 bis 150

-Vereinfacht das Verfahren für die Befestigung von Durchführungen aus Porzellan

-Die Verringerung der Anzahl von Teilen und die Schnelligkeit der Montage erlauben eine signifikante Absenkung der Installationskosten.

-Sehr robust

-Erlaubt einen guten Durchfluß des Öls

-Messingstange für die Befestigung (1), wird auf Bestellung geliefert.

Para transformador en aceite, soporte de aisladores de porcelana BT

- para cualquier estándar de 160A a 630A;

- modelo sencillo y múltiple con distancia entre ejes fija de 55 a 150;

- Simplifica el método de fijación de los aisladores de porcelana;

- La reducción del número de piezas necesarias y la rapidez del montaje permiten una significativa disminución de los costes de instalación;

- Muy robusto;

- Permite una buena circulación del aceite;

- varilla de latón para la fijación (1), se suministra a petición.

42150220 - E150 - Ø20 - H35

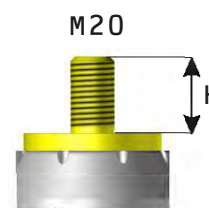
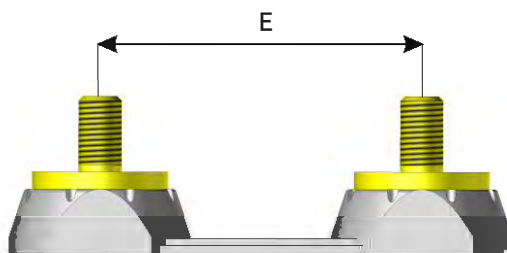
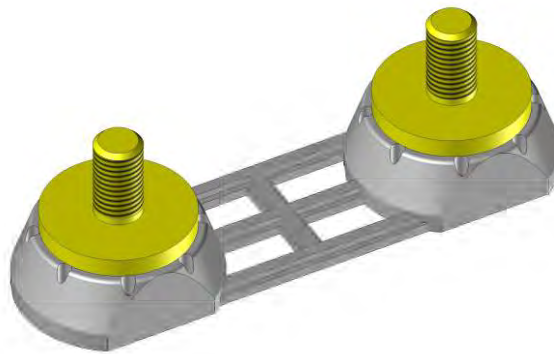

Busbar Support Schienenstütze - Portabarra

Pièce de connexion, pour transformateur BT et porte barre d'armoire.
 Piece for connexion, for LV Transformer. Busbar support for electrical cabinet.
 Verbindungstück zwischen dem Joch des transformators und der schiene.
 Schienenstütze für Schaltschrank.
 Pieza de conexion, para Transformador BT - Portabarra de armario

Classe F

Code	A	B	C
18FN0401054	40	54	M10
18FN0500854	50	54	M08
18FN0501054	50	54	M10
18FN0501254	50	54	M12
18FN0600854	60	54	M08
18FN0601054	60	54	M10
18FN0601254	60	54	M12
18FN0601260	60	60	M12
18FN0601460	60	60	M14
18FN0700865	70	65	M08
18FN0701065	70	65	M10
18FN0701265	70	65	M12
18FN0800854	80	54	M08
18FN0801054	80	54	M10
18FN0801254	80	54	M12

29PL0300F - Peigne de Support 03
29PL0400F - Peigne de Support 04
29PL0500F - Peigne de Support 05

18 -BAS - SUPPORT de BARRE

Transformateurs "Sec" / Dry type transformer / Trockentransformator / Transformator Tipo Seco

Busbar Support Schienenstütze - Portabarra

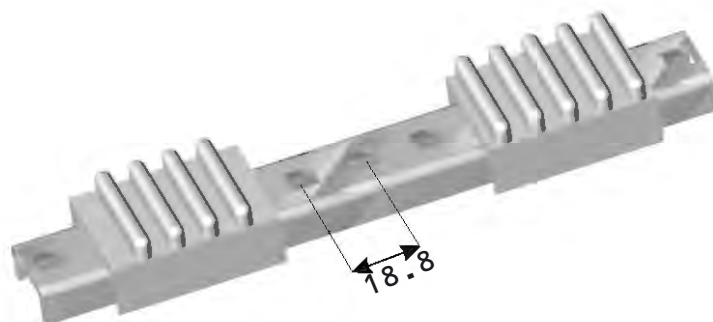
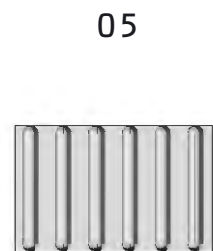
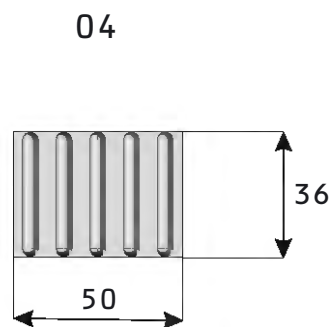
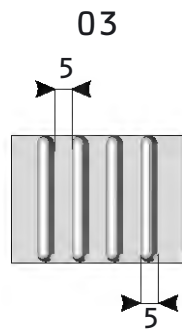
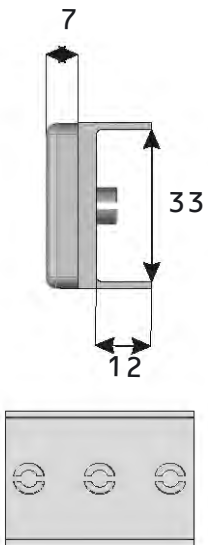
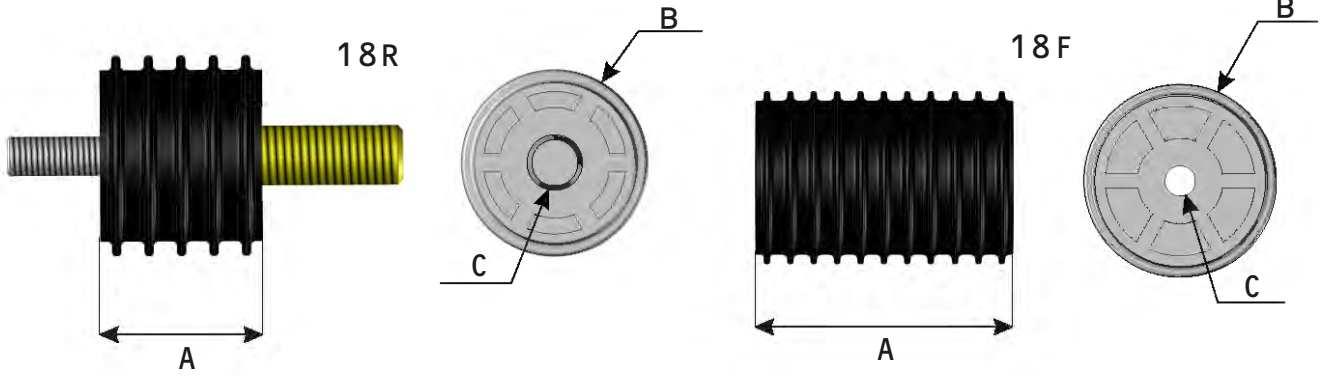

Spacers - Abstandshalter - Espaciadores

Pour transformateurs "secs", en calage et espacement entre spires.
Le matériau composant ces cales "PBT" est adapté pour la classe H.

Leur mise en place par un simple clipsage ou coulissage, permet une réduction importante des temps de pose.

Leurs Canaux de refroidissement améliorent la ventilation des bobinages.

Leurs propriétés mécaniques (résistance à l'écrasement et à la flexion = bonne absorption des chocs) leur permettent de supporter parfaitement les efforts dynamiques résultant du fonctionnement du transformateur, ou se produisant en court-circuit

Elles assurent ainsi le calage et le maintien des bobinages.

Nous pouvons fournir des modèles adaptés à vos profilés

For "Dry Type" transformers, for supporting and spacing between windings.

The material used for these spacers "PBT" is suitable for class H.

It's very easy to fit them thanks to a simple champing of sliding; so they allow to reduce significantly fitting times.

Their cooling ducts improve the winding ventilation.

Their mechanical properties (crushing and bending strenght = good shock absorption) provide them a perfect resistance to dynamic stresses which result from the transformer operation, or which happen in case of short circuit.

That is how they provide winding supporting, keeping them in position.

We can supply you with models suitable to your shapes

Référence - Reference Referenz - Referencia	Profilé	Matières	Cote A	Longueur total X Largeur	Epaisseur
20CH504406	Hutprofile	PBT	40	50x44	6
20CH554406	Hutprofile	PBT	45	55x44	6
20CH604406	Hutprofile	PBT	50	60x44	6
20CH654406	Hutprofile	PBT	55	65x44	6
20CH654409	Hutprofile	PBT	55	65x44	9
20CH704406	Hutprofile	PBT	60	70x44	6
20CH804406	Hutprofile	PBT	70	80x44	6
200S374495	DogBone 10x13	PBT	32	37x44	9.5
200S464495	idem	PBT	41	46x44	9.5
200S624495	idem	PBT	57	62x44	9.5
20R0504106	Rond 16 *	PBT	42*	50x41	6
20R0703508	Rond 17 *	PBT	53*	70x36	8

* Axe

Spacers - Abstandshalter - Espaciadores

Für trocken-Transformatoren zum Verkeilen und Abstandhalten zwischen Windungen. Der werkstoff des "PTB"-Verkeilungen ist für die Klasse H geeignet.

Das Anbringen durch einfaches Clipsen oder Gleiten erlaubt eine große Verringerung der Durchführungszeiten.

Die Kühlkanäle verbessern die Belüftung der wicklungen.

Die mechanischen Eigenschaften (Kompressions- und biegefestigkeit = Gute Stoßabsorption) erlauben es den Verkeilungen, den dynamischen Kräften, die sich aus dem Betrieb des transformators oder bei einem kurzschluss ergeben, perfekt standzuhalten.

Sie gewährleisten das Verkeilen und das Halten der Wicklungen.

Wir liefern auch Modelle, die an Ihre profile angepasst Werden.

Para transformadores de "tipo seco", para calzar y espaciar las espiras de bobinados. El material que compone esos espaciadores "PBT" es adaptado para clase H.

Su montaje por simple presión o deslizamiento, permite una reducción importante de los tiempos de colocación.

Sus canales de enfriamiento mejoran la ventilación de los enrollamientos.

Sus propiedades mecánicas (resistencia al aplastamiento y a la flexión = buena absorción de los choques) les permiten soportar perfectamente los esfuerzos dinámicos que resultan del funcionamiento del transformador o que se producen en caso de corto circuito.

Así aseguran el calzamiento y el sostenimiento de los enrollamientos.

Les podemos suministrar modelos adaptados a sus perfiles.

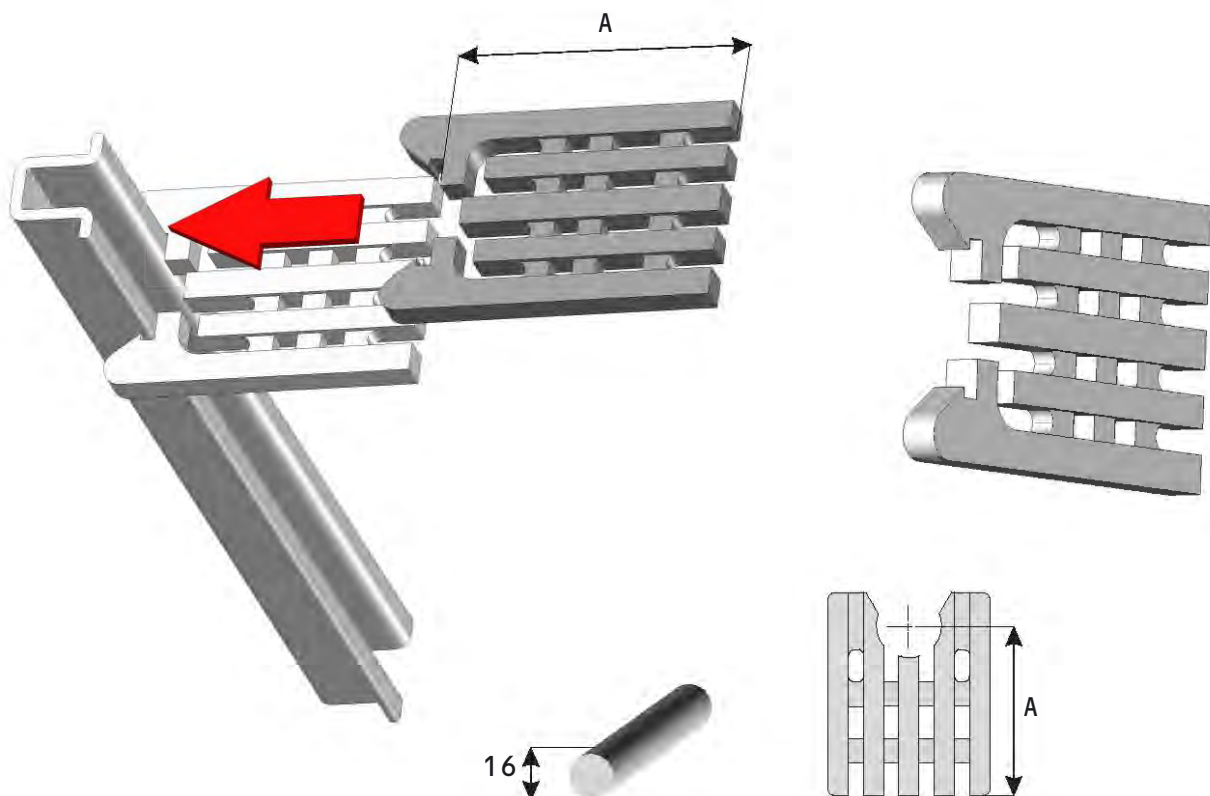

Transformateur "Résine" / Cast Resin Transformer / Gießharztransformator / Transformator encapsulado

Coils Support - Enddistanzstück - Soporte de Bobina

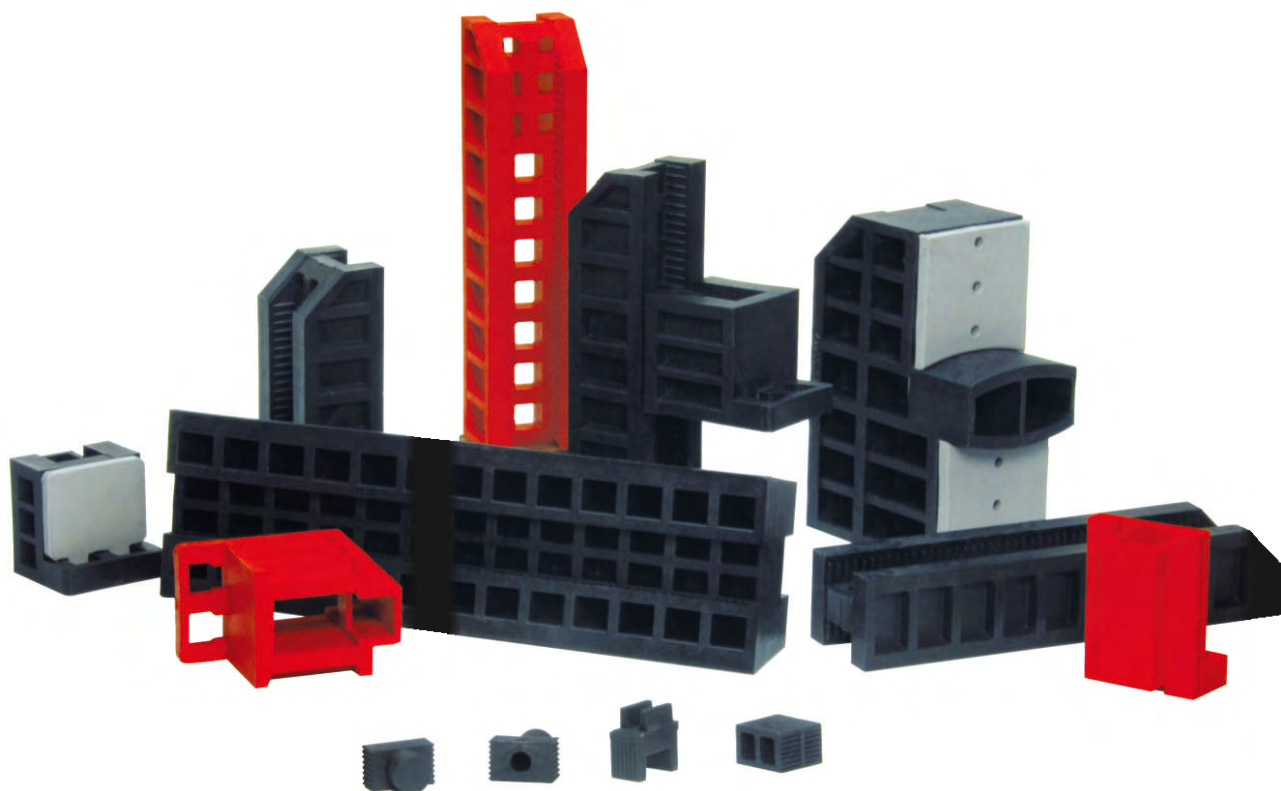

Pièces standard - Classe F (155°C) en noir - sur demande en rouge
 Standard pieces - Classe F (155°C) in black - on request in red color
 Standardmodell - Klasse F (155°C) in schwarz - Auf Anfrage Rot
 Piezas de serie - Clase F (155°C) en negro - Según petición color rojo

ASSEMBLIES - MONTAGEN - CONJUNTOS

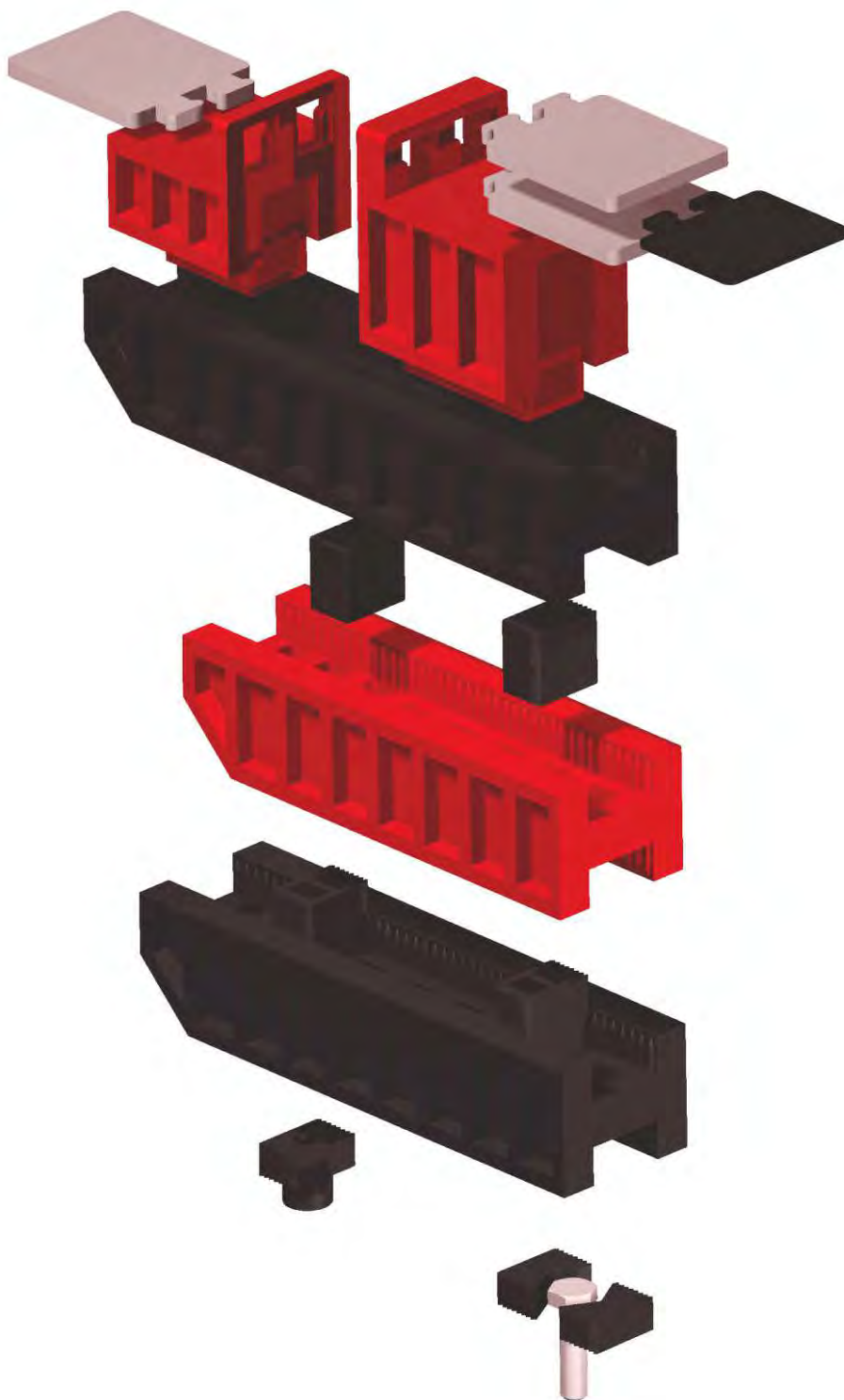

Pour transformateurs résines, également appelés enrobés.
Ces supports de bobines permettent différents agencements et conviennent à tout type de puissance et de tension

De conception "Design" ces cales crantées assurent un calage efficace des bobines évitant tout jeu de mouvements lors du transport de transformateurs et de se son utilisation sur site. Elles sont particulièrement résistantes et bien ventilées et répondent aux principales conditions d'utilisations dans les transformateurs.

For resine transformers, these cast coil supports enable various arrangements and are suitable for every power and voltage.

With an esthetic design, these supports ensure an efficient fixing of the windings while avoiding any slight play of the windings the transport of the transformer and its utilization on site.

They are particularly resistant, well ventilated and meet the major conditions of use in the transformers.

I) La cale Monobloc - (43)

I) Monoblock supports - (43)

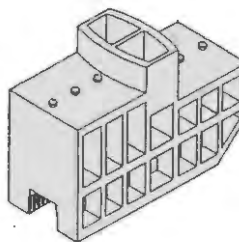

II) La Cale "Multi-agencements" - (28 et 30)

II) Multi-arrangement supports - (28 & 30)

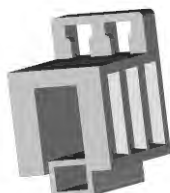

III) Nouvelle génération de cales "Multi-agencement" - (31)

III) New generation of multi-arrangement supports - (31)

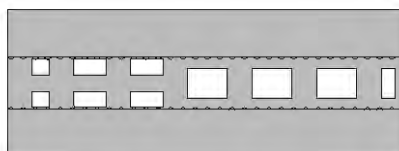

Für trockenstransformatoren auch gennant Giesshartztransformatoren. Diese isolierstützen erlauben verschiedene anordnungen und sind für jede Leistung und Spannung verwendbar.

Mit einem ästhetischen Empfänger, sie befestigen wirksamlich die Spulen und Meiden Spiel während des transports des transformators und seine Benutzung am Platz zu haben. Mit einer guten Belfüttung und besonders beständig, sie entsprechen den Hauptbedingungen in der Transformatorbenutzung.

Para transformadores secos, también llamados encapsulados. Estos soportes de bobina permiten diferentes disposiciones y son convenientes para cualquier tipo de potencia y tensión.

De concepción "Design", estos soportes de bobina aseguran un apuntalamiento eficaz de las bobinas mientras evitan cualquier juego de movimientos durante el transporte del transformador y su utilización en sitio. Son particularmente resistentes, bien ventilados y cumplen con las principales condiciones de utilización en los transformadores.

I) Monoblock-stütze - (43)

I) El taco monobloque - (43)

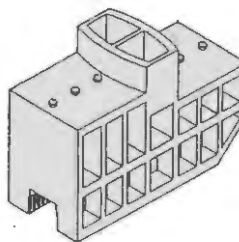

II) Vielanordnungen-stütze - (28 et 30)

II) El taco "multidisposiciones" - (28 & 30)

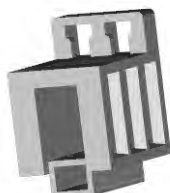

III) Neue Generation von Vielanordnungen-stützen - (31)

III) Nueva generación de tacos "Multiposiciones" - (31)

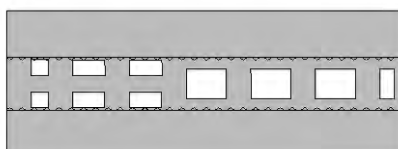

Transformateur "Résine" / Cast Resin Transformer / Gießharztransformator / Transformator encapsulado

Bottom Spacer - Grundkeile - Cùna

28B06040 L60	28B08040 L80	28B10040 L100	28B12040 L120
------------------------	------------------------	-------------------------	-------------------------

28B13040 L130	28B14040 L140	28B16040 L160	28B18040 L180
-------------------------	-------------------------	-------------------------	-------------------------

28020040 L200	28B22040 L220
-------------------------	-------------------------

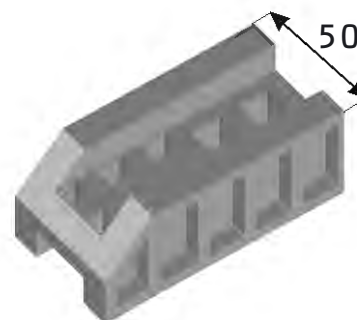
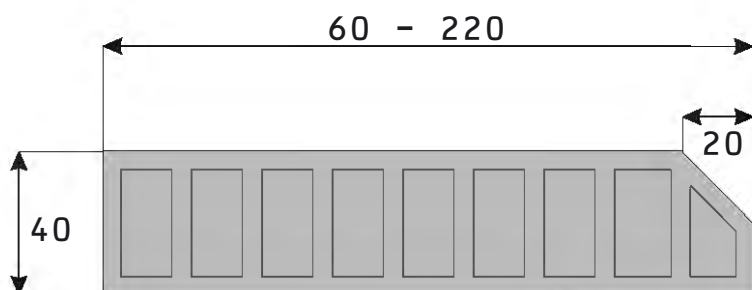

30B18050
L180 - La70 - H50

30B18060
L180 - La 70 - H60

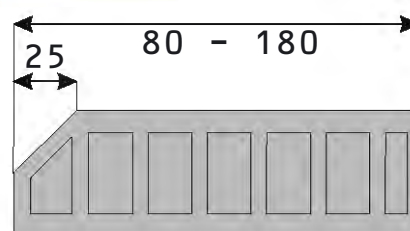
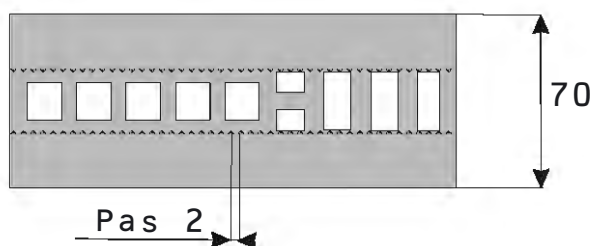

31B27040/80
L 270 - La80 - H40

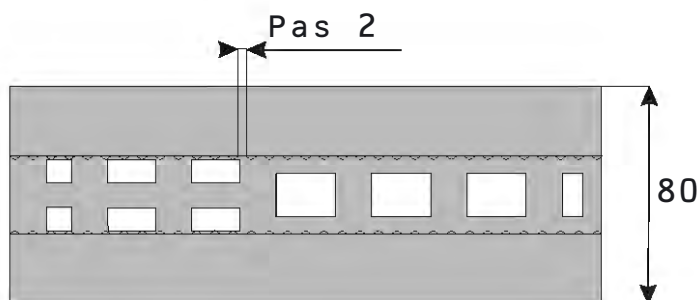

Connecting Parts - Anschlußstück - Piezas de Conexión

28T60100

A25 - B17 - C10

Butée de vérin
Jack stop
Windenschlag
Tope de gato

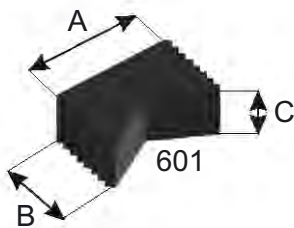

28T60200

X10 - Y16

Doigt de centrage
Fixing finger
Befestigungsfinger
dedo de fijacion

28T60500

X15 - Y16

Doigt de centrage
Fixing finger
Befestigungsfinger
dedo de fijacion

28T60600

X25 - Y22

Doigt de centrage
Fixing finger
Befestigungsfinger
dedo de fijacion

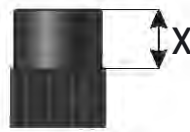

602 - 605 - 606

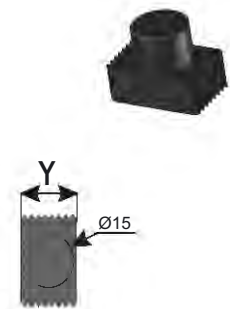

28T60300

23x16

Taquet de liaison
Connecting part
Anschlußstück
Taco de conexion

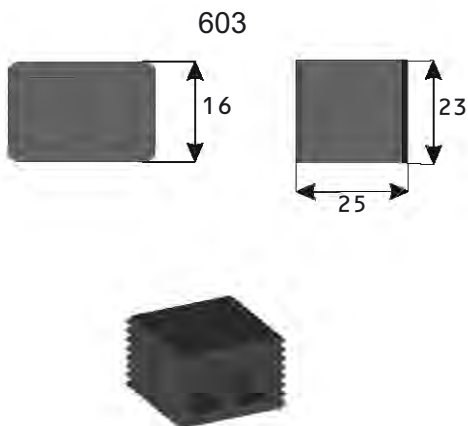

28T60400

26x14 H10

28T604NB

26x14 H18

Support d'écran
Screen support
Mutterstutze
Soporte de pantalla

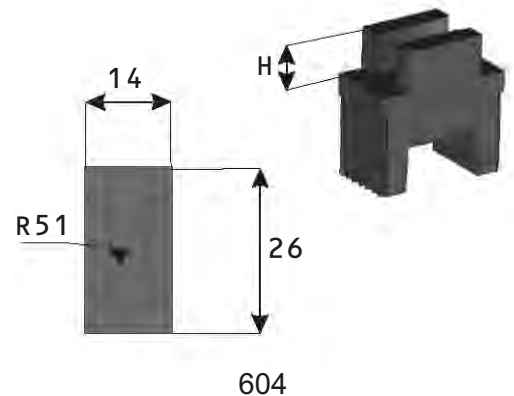

Transformateur "Résine" / Cast Resin Transformer / Gießharztransformator / Transformator encapsulado

Coils Support - Enddistanzstück - Soporte de Bobina

28N00920 N09 B20	28N00930 N09 B30	28N00940 N09 B40	28N00945 N09 B45	28N00955 N09 B55	28N00960 N09 B60
28N00970 N09 B70	28N00985 N09 B85	28N01555 N15 B55		28N02035 N20 B35	28N02040 N20 B40
28N02045 N20 B45	28N02545 N25 B45	28N02555 N25 B55	28N02570 N25 B70	28N03030 N30 B30	28N03040 N30 B40
28N03520 N35 B20	28N03540 N35 B40	28N03555 N35 B55	28N03560 N35 B60	28N03570 N35 B70	
28N04040 N40 B40	28N04065 N40 B65	28N04090 N40 B90		28N04560 N45 B60	28N04740 N47 B40
28N05040 N50 B40	28N05055 N50 B55	28N05060 N50 B60	28N05740 N57 B40		
28N7250 N72 B50	28N8040 N80 B40				

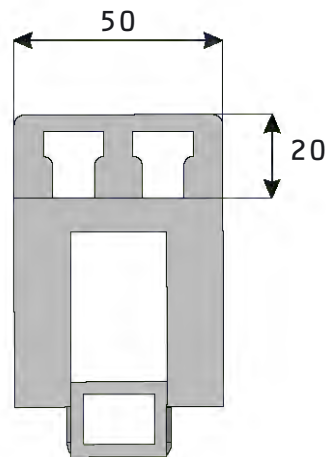
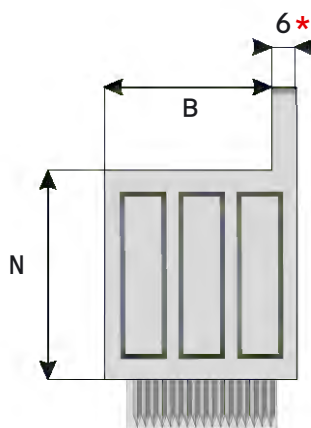
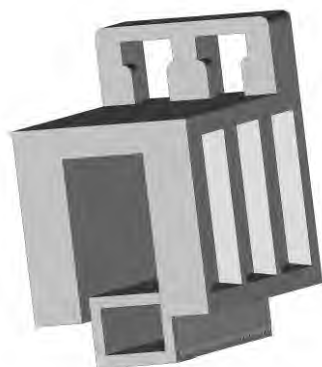

Pièces standard en noir - sur demande en rouge
 Standard pieces in black - on request in red color
 Standardmodell in schwarz - Auf Anfrage Rot
 Piezas de serie en negro - Segú petición color rojo

28N*XXXX
 N = 6
 D = 9
 I = 10
 C = 12



Coils Support - Enddistanzstück - Soporte de Bobina

28C00920	28C00930	28C00940	28C00950	28C00955	28C00960
H09 B20	H09 B30	H09 B40	H09 B50	H09 B55	H09 B60

28C01540	28C02040	28C02055	28C02540	28C02555	28C03020
H15 B40	H20 B40	H20 B55	H25 B40	H25 B55	H30 B20

28C03030	28C03040	28C03050	28CH3055	28C03060	28C03080	28C03540
H30 B30	H30 B40	H30 B50	N30 B55	H30 B60	H30 B80	H35 B40

28C03555	28C04030	28C04040	28C04050	28C04540	28C04055
H35 B55	H40 B30	H40 B40	H40 B50	H45 B40	H40 B55

28C04540	28C04555	28C04740	28C05020	28C05030	28C05040
H45 B40	H45 B55	H47 B40	H50 B20	H50 B30	H50 B40

28C05050	28C05055	28C05060	28C05555	28C05740	28C05755
H50 B50	H50 B55	H50 B60	H55 B55	H57 B40	H57 B55

28C06035	28C06055	28C06240	28C06250	28C07250	28C07255	28C10740
H60 B35	H60 B55	H62 B40	H62 B50	H72 B50	H72 B55	H107 B40

30C01070	30C01555	30C01570	30C03070	30D01030	30D02540
H10 B70	H15 B55	H15 B70	H30 B70	H10 B30	H25 B40
La 70	La 70	La 70	La 70	La 70	La 70

31I03050/80	31I03090/80
H30 B50	H30 B90
La 80	La 80

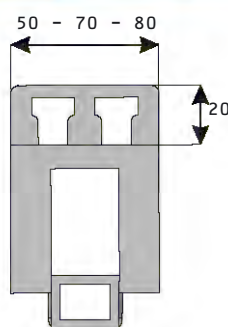
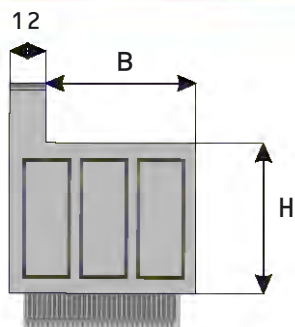

28N*XXXX
N = 6
D = 9
I = 10
C = 12



Transformateur "Résine" / Cast Resin Transformer / Gießharztrasformator / Transformator encapsulado

Coils Support - Enddistanzstück - Soporte de Bobina

28P00980 P09 B80	28P009100 P09 B100	28P01540 P15 B40	28P01580 P15 B80	
28P02040 P20 B40	28P020100 P20 B100	28P025100 P25 B100	28P03045 P30 B45	28P04080 P40 B80

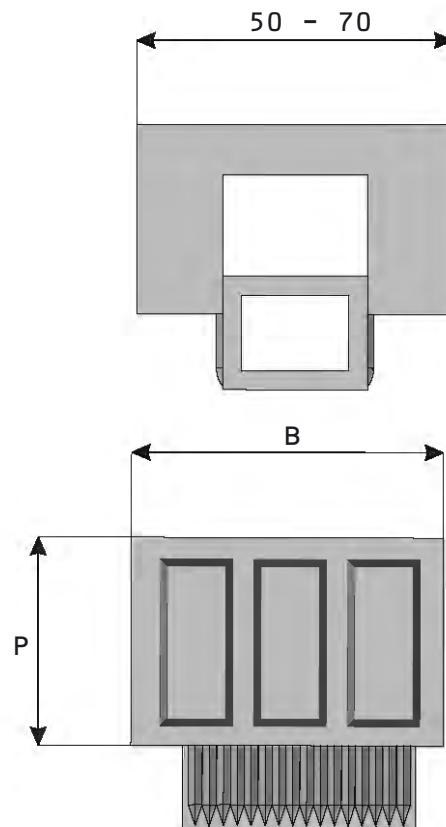
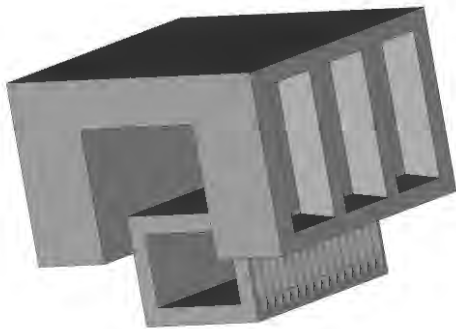

28 - 30 - 31 - 43 - Entretoise

Brace - Abstandshalter - Tirante

28E40501 H= 40 L= 50 Ep.= 1	28E40502 H= 40 L= 50 Ep.= 2	28E55501 H= 55 L= 50 Ep.= 1	28E55502 H= 55 L= 50 Ep.= 2
---------------------------------------	---------------------------------------	---------------------------------------	---------------------------------------

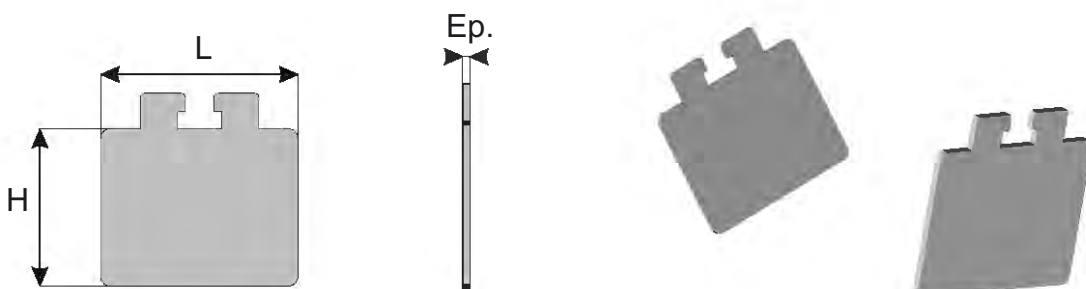

Transformateur "Résine" / Cast Resin Transformer / Gießharztransformator / Transformator encapsulado

Shocks Absorber - Stoßdämpfer - Amortiguador

28A205010	28A305010	28A355010	28A4050.05 & 10	28A455010	28A505010	28A5550.05 & 10
20.50/10	30.50/10	35.50/10	40.50/05 & 10	45.50/10	50.50/10	55.50/05 & 10

28A6050.05 & 10	28A655010	28A705005	28A705010
60.50/05 & 10	65.50/10	70.50/05	70.50/10

28A805005 & 10
80.50/05 & 10

30A557010	30A707010	30A1008005
70.55/10	70.70/10	100.80/05

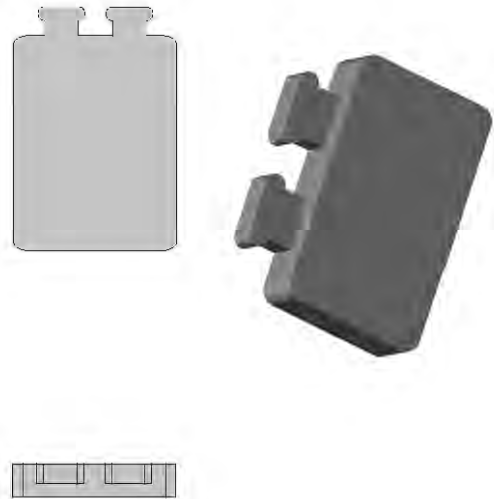

30AP455010	30AP508010	30AP908010
45.50/10	50.80/10	90.80/10

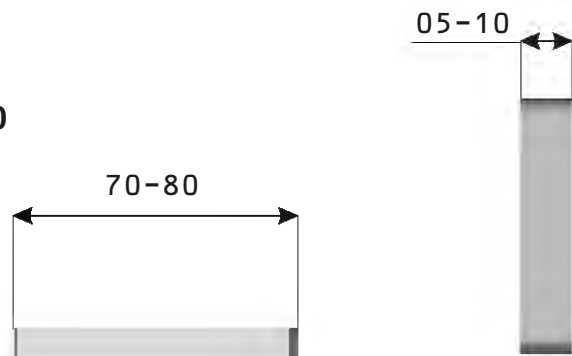

Block Support - Aufbaublock - Taco Bloque

43CK09425

A	150 ±0.5
B	062 ±0.5
C	075 ±0.5
D	055 ±0.5
E	056 ±0.5
F	056 ±0.5

43CK09426

	150 ±0.5
	062 ±0.5
	088 ±0.5
	068 ±0.5
	056 ±0.5
	056 ±0.5

+28T60500

43CK09430

	125 ±0.5
	062 ±0.5
	088 ±0.5
	068 ±0.5
	044.2±0.5
	044.2±0.5

+28T60500

43CK09431

	125 ±0.5
	062 ±0.5
	075 ±0.5
	055 ±0.5
	044 ±0.5
	044 ±0.5

43CK12628

A	105.5±0.5
B	062 ±0.5
C	049 ±0.5
D	051 ±0.5
E	049 ±0.5
F	050 ±0.5

43CK12629

	105.5±0.5
	062 ±0.5
	069 ±0.5
	051 ±0.5
	049 ±0.5
	050 ±0.5

+28T60500

43CK12630

	118 ±0.5
	062 ±0.5
	049 ±0.5
	063.5±0.5
	025.5±0.5
	063.5±0.5

43CK12631

	118 ±0.5
	062 ±0.5
	075 ±0.5
	063.5±0.5
	025.5±0.5
	063.5±0.5

+28T60500

43CK12632

A	120 ±0.5
B	062 ±0.5
C	074 ±0.5
D	063.5±0.5
E	025.5±0.5
F	063.5±0.5

43CK12633

	120 ±0.5
	062 ±0.5
	094.5±0.5
	063.5±0.5
	025.5±0.5
	063.5±0.5

+28T60500

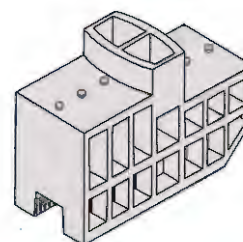

43CK14235

A	183 ±0.5
B	063.5±0.5
C	076 ±0.5
D	059 ±0.5
E	078.5±0.5
F	067.5±0.5

43CK14236

	183 ±0.5
	063.5±0.5
	089 ±0.5
	068.5±0.5
	078.5±0.5
	067.5±0.5

+28T60500

43CK014237

	195.5±0.5
	063.5±0.5
	076 ±0.5
	059 ±0.5
	077.5±0.5
	073.5±0.5

43CK14238

	195.5±0.5
	063.5±0.5
	089 ±0.5
	068.5±0.5
	077.5±0.5
	073.5±0.5

+28T60500

Transformateur "Résine" / Cast Resin Transformer / Gießharztransformator / Transformator encapsulado

Block Support - Aufbaublock - Taco Bloque

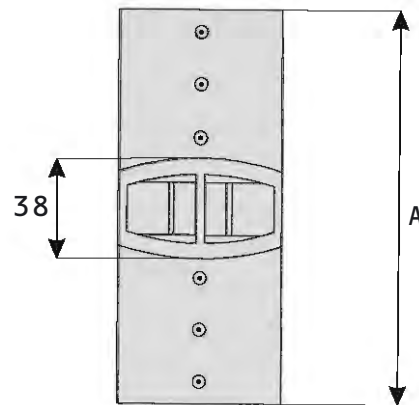
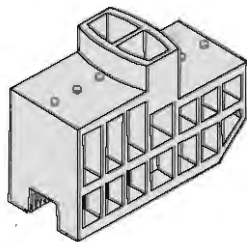
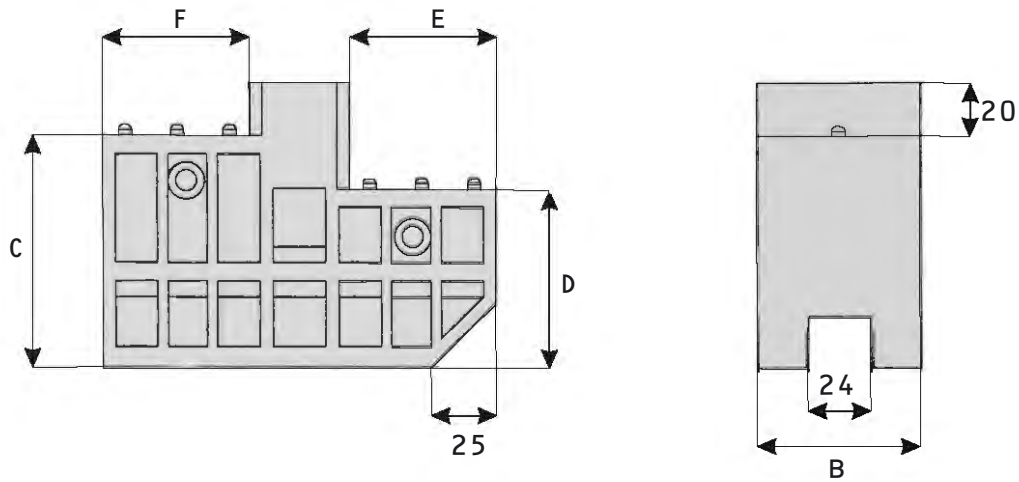

43AP02526	43AP03031	43AP62A25	43AP62B51	43AP62C64
94 type 55	94 type 44	126 type A	126 type B	126 type C

43AP35B226	43AP35H136	43AP37B438	43AP37B438
142 B2	142 H1	142 B4	142 H3

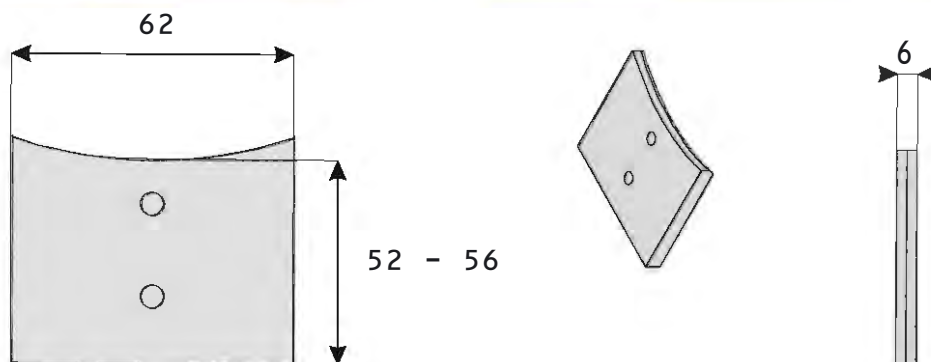

NOTES



pioch

1^{ere} Avenue – 3^e Rue
B.P. 408
06515 CARROS Cedex 1
FRANCE

Tel. +33 (0) 493 290 725
Fax +33 (0) 493 292 211
piochsas@pioch.fr
www.pioch.com

